

How to Program WONDOM ADAU1701 JAB5 with SigmaStudio

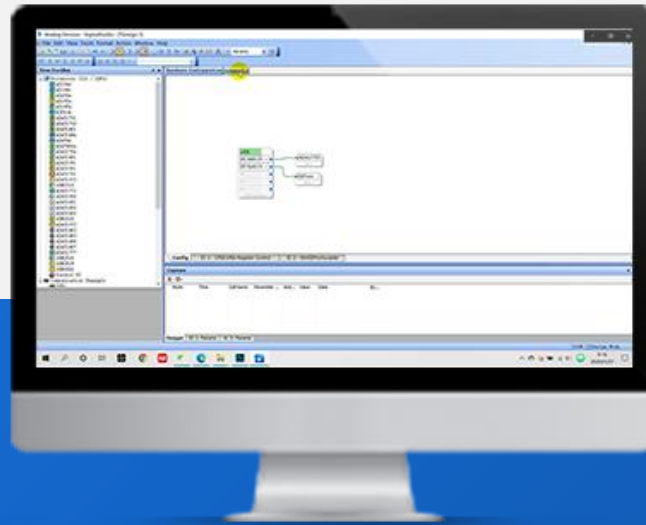
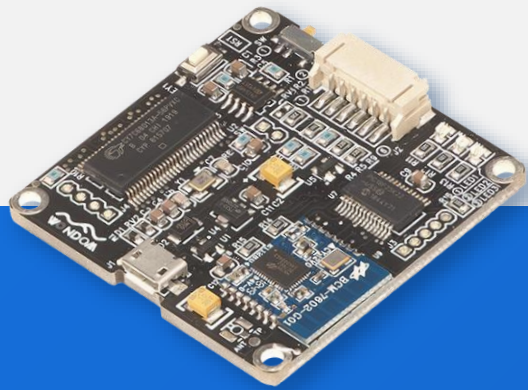

Before Reading

JAB5 is an audio amplifier board integrated with both Bluetooth and ADAU1701 DSP, which supports configuration as 4.0/2.1/2.0/0.2 output mode. You can program JAB5 with SigmaStudio. Since JAB5 employs Bluetooth, extra attention needs to be paid to the programming.

The purpose of this document is to give you instructions on how to program JAB5 with SigmaStudio.



CORRESPONDENCE



It is essential to know the correspondence relationship between the resources of JAB5 hardware and ADAU1701 program before you want to re-write the program.



AUDIO SETTINGS



You need to complete the audio settings before programming so that JAB5 can work normally after re-writing program.



PROGRAM



We will list out which settings are necessary, which are optional and will give some suggestions.

Preparations

We will need the following stuff at hand before we start.

1 WONDOM JAB5 & ICP3/ICP1



JAB5

ICP1

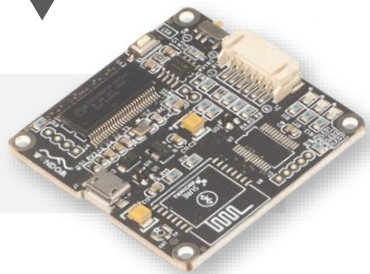

OR

ICP3

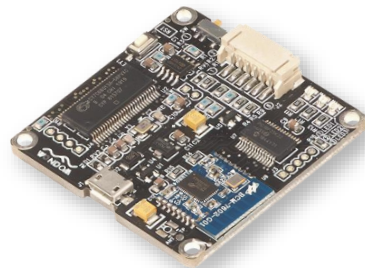

2 SigmaStudio Software

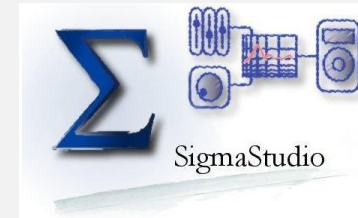

Analog Devices, Inc.
SigmaStudio™

3 Demo Program of JAB5

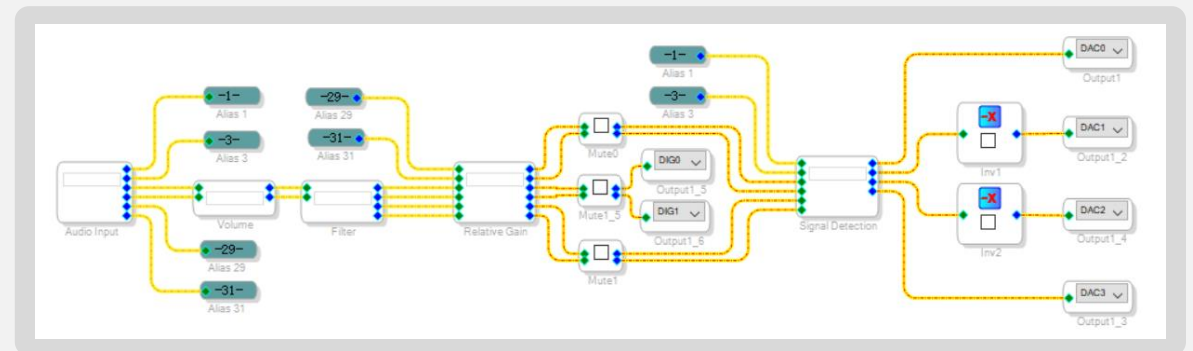

You can see the hardware configuration and schematic in the demo program. Click [HERE](#) to download.

Correspondence

To make it more instinct and easier for understanding, we will make use of the demo program of JAB5 to explain the relationship of the hardware and ADAU1701 program.

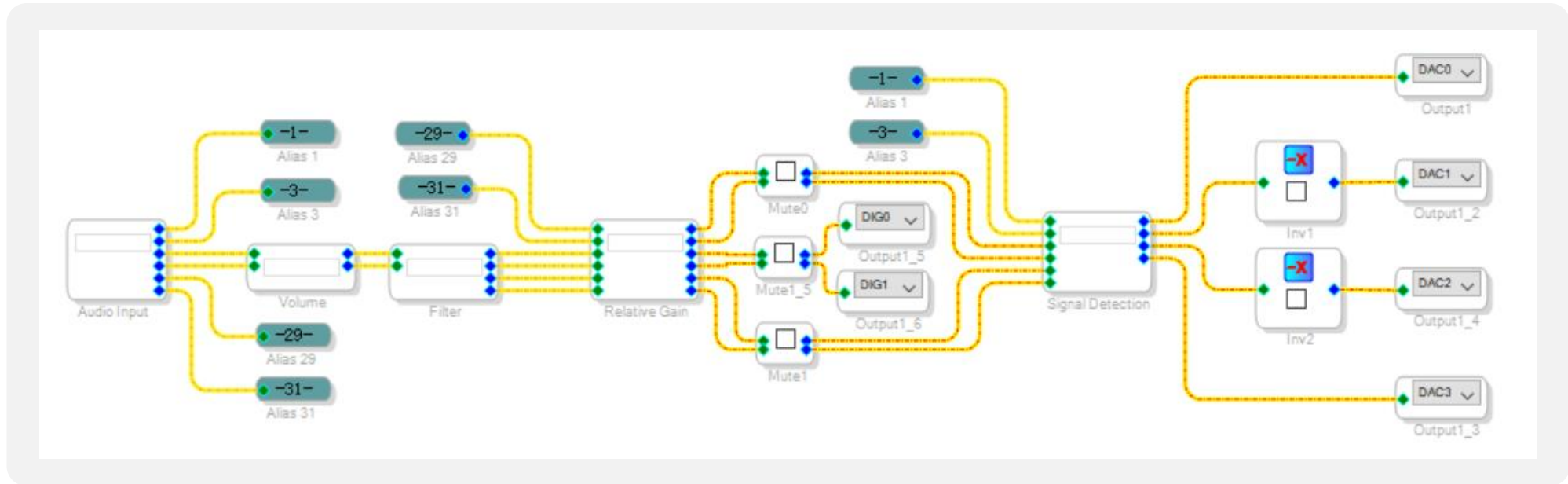

This is the demo program in the SigmaStudio. We will introduce to you in the following order.



Audio Input



Audio Output



Potentiometers



Signal Detection



Audio Input

JAB5 supports both Bluetooth input, 3.5mm line input and I2S input. The Bluetooth and I2S input are switched by SW1.

3.5mm AUX IN

JAB5 supports analog input, J5 is used for 3.5mm AUX IN.

I2S Input

I2S input (J6) is supported in JAB5.
When SW1 is set at Master mode, I2S input would be disabled.
When SW1 is set at Slave mode, I2S input would be enabled.

Bluetooth Input

Bluetooth V5.0 module
When SW1 is set at Master mode, Bluetooth input would be enabled.
When SW1 is set at Slave mode, Bluetooth input would be disabled.

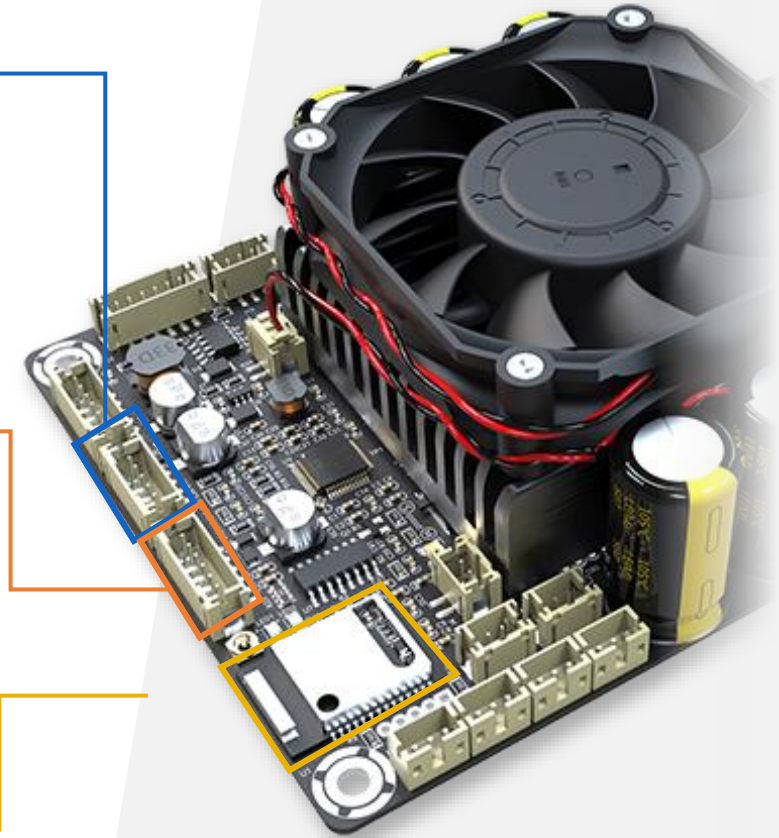



Audio Input

The Bluetooth and I2S input are switched by SW1.

SW1	JAB5 Mode	BT Input	I2S Input	I2S Output	External MCLK
M	Master	Enabled	Disabled	Enabled	Not Needed
S	Slave	Disabled	Enabled	Enabled	Needed*

* If JAB5 is set as Slave mode, an external MCLK is required.

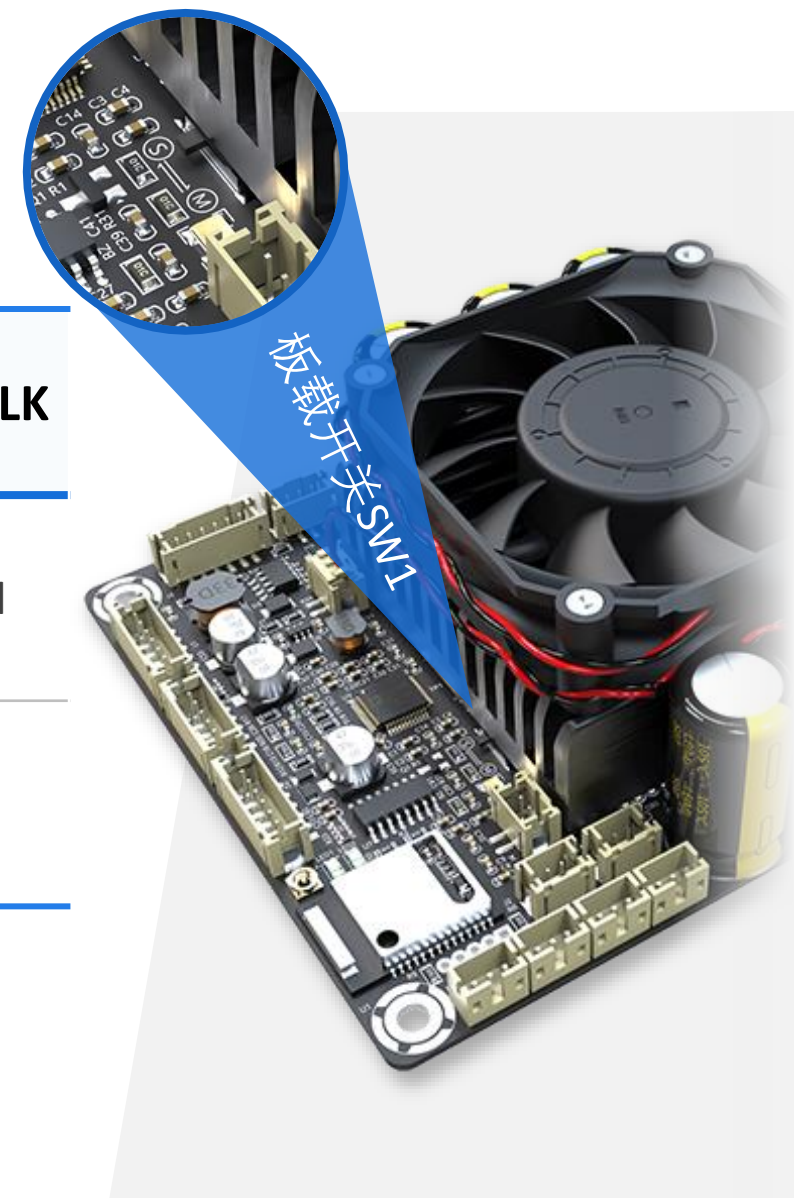



Audio Input

You can see the input configuration in the “Audio Input” part in the demo program.

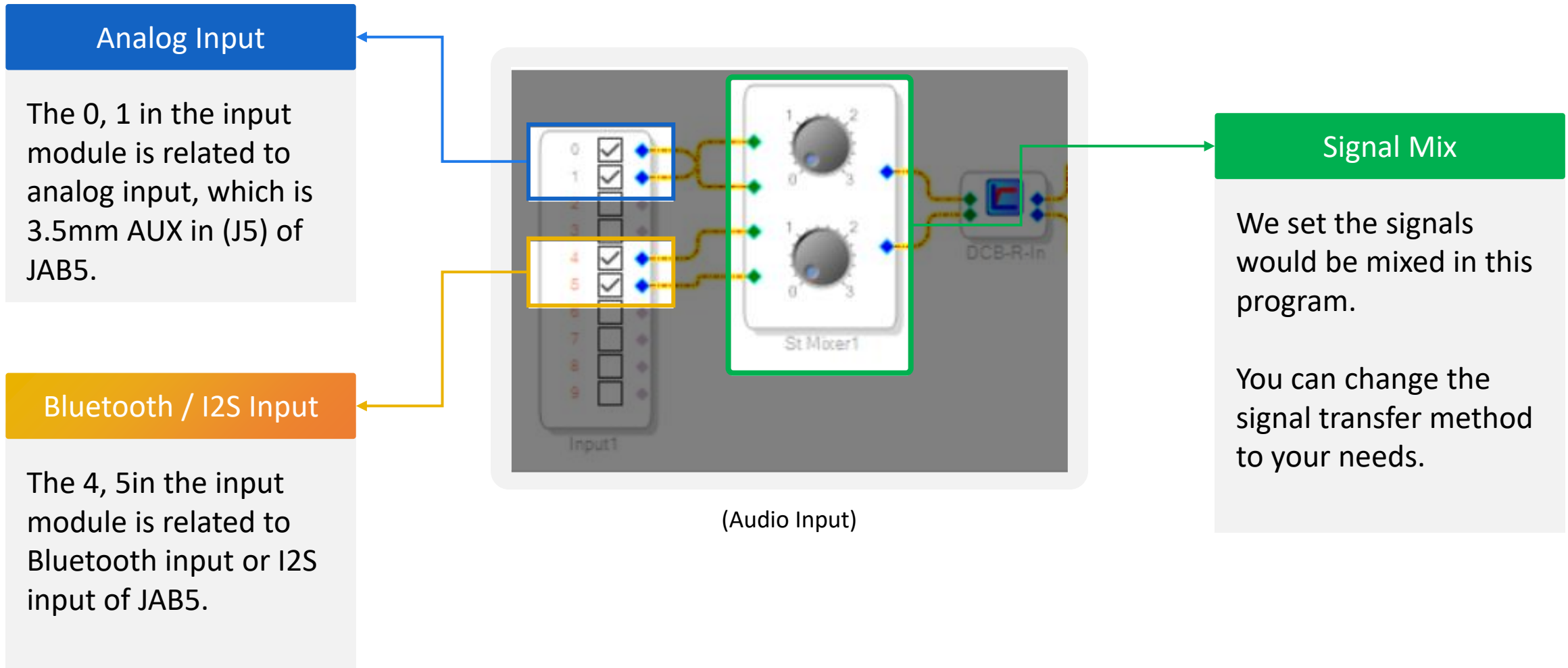



Audio Output – Speaker Output

JAB5 can support configuration as 4.0/2.1/2.0/0.2 mode, which is achieved by auto cable identification system.

J13 and J14 are connectors for speaker connection.

As we can see from the right chart, when position 3 and position 6 are short circuit, the output will work as stereo; when they are open, the output will work as mono.

There are two speaker cables in the package of JAB5, with which, you can switch the output mode easily.

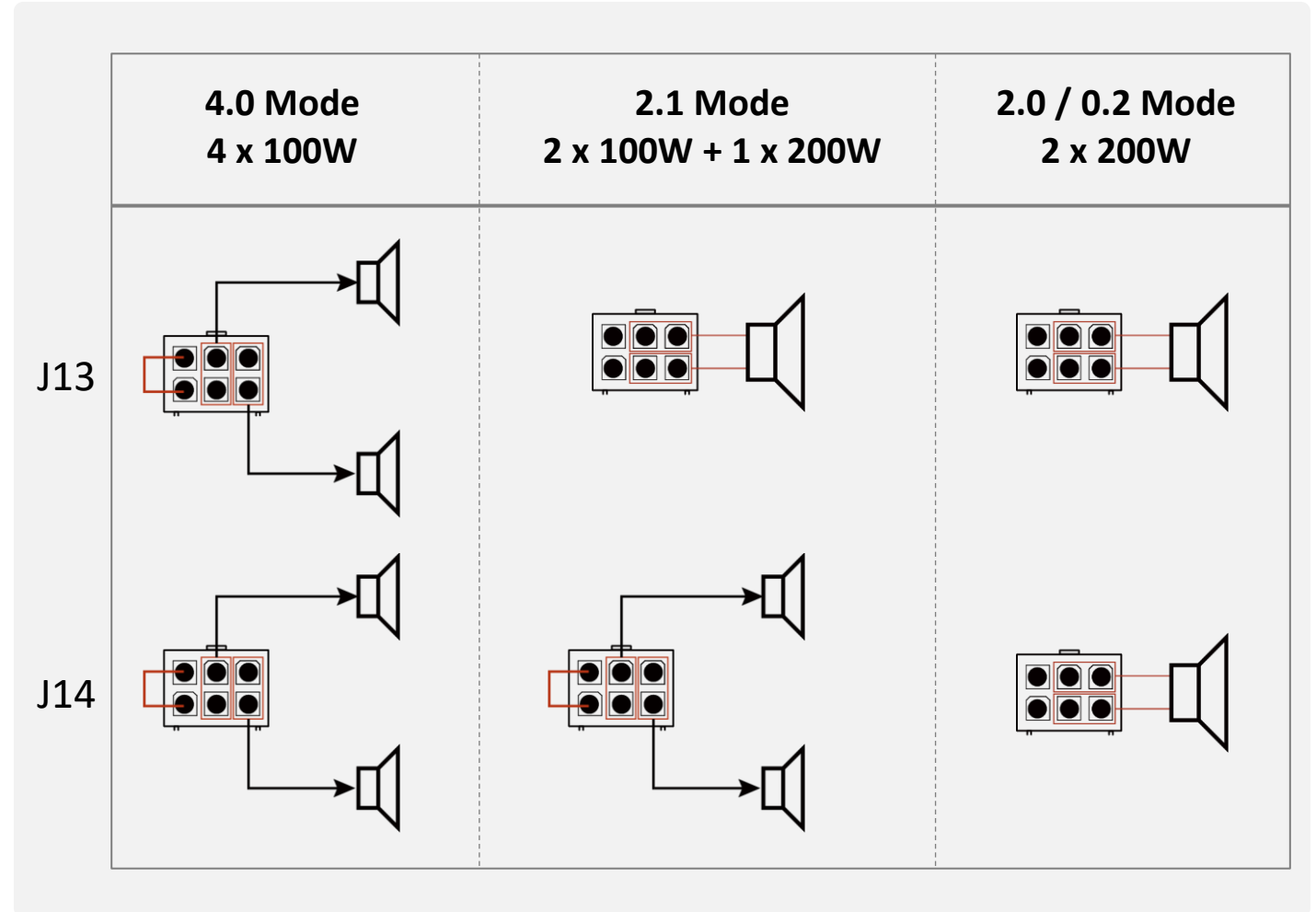



Audio Output – Speaker Output

You can see the program for output in the “Main” part.

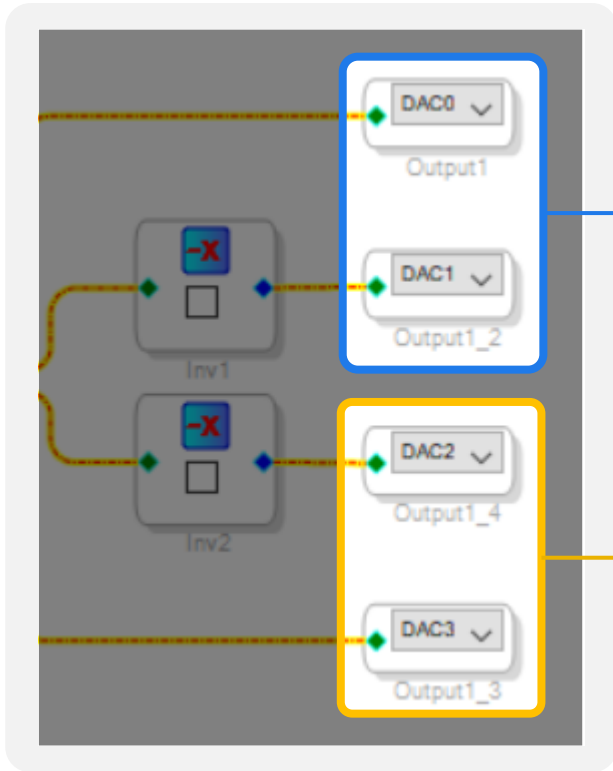

(Main)

J14 - Speaker Output

DAC0 and DAC1 are corresponding to power amplifier output (J14) of JAB5.

J13 - Speaker Output

DAC2 and DAC3 are corresponding to power amplifier output (J13) of JAB5.

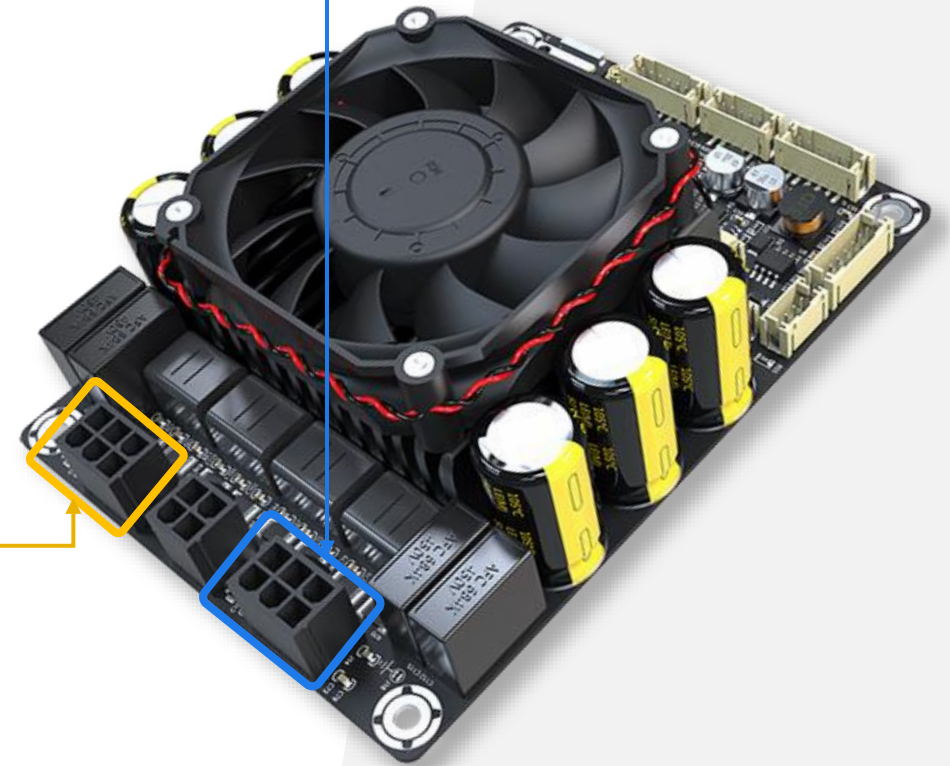



Audio Output – Speaker Output

We have used two GPIOs to detect the signal level to see the output is set as stereo or mono. You can see this part of program in the “Output”.

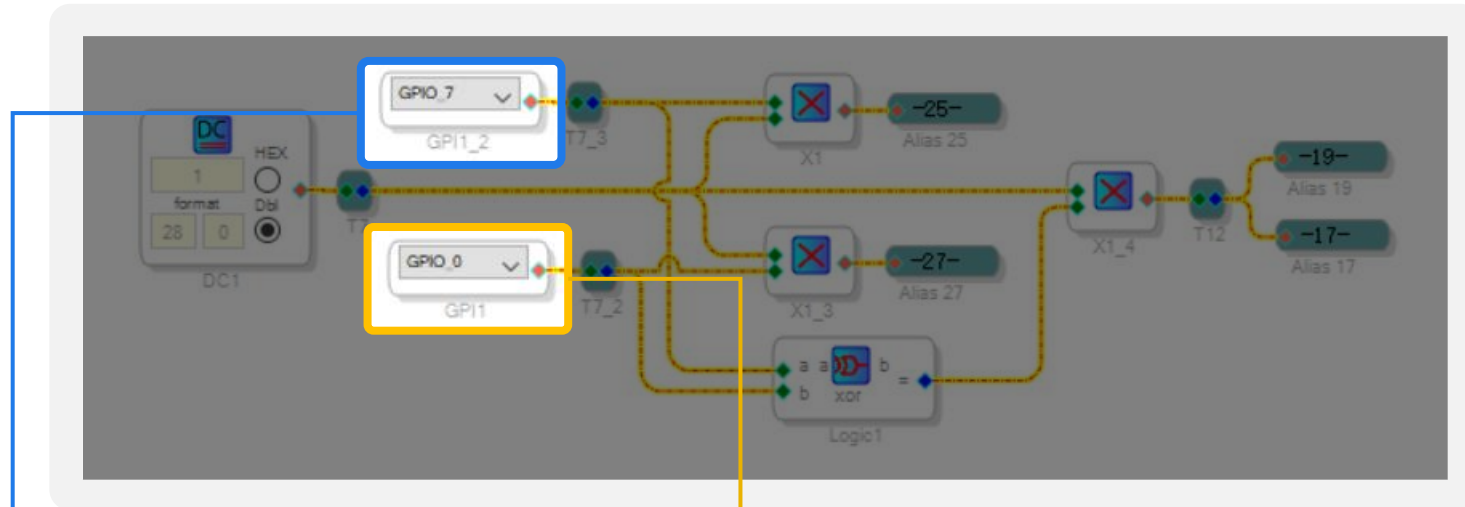

(Output)

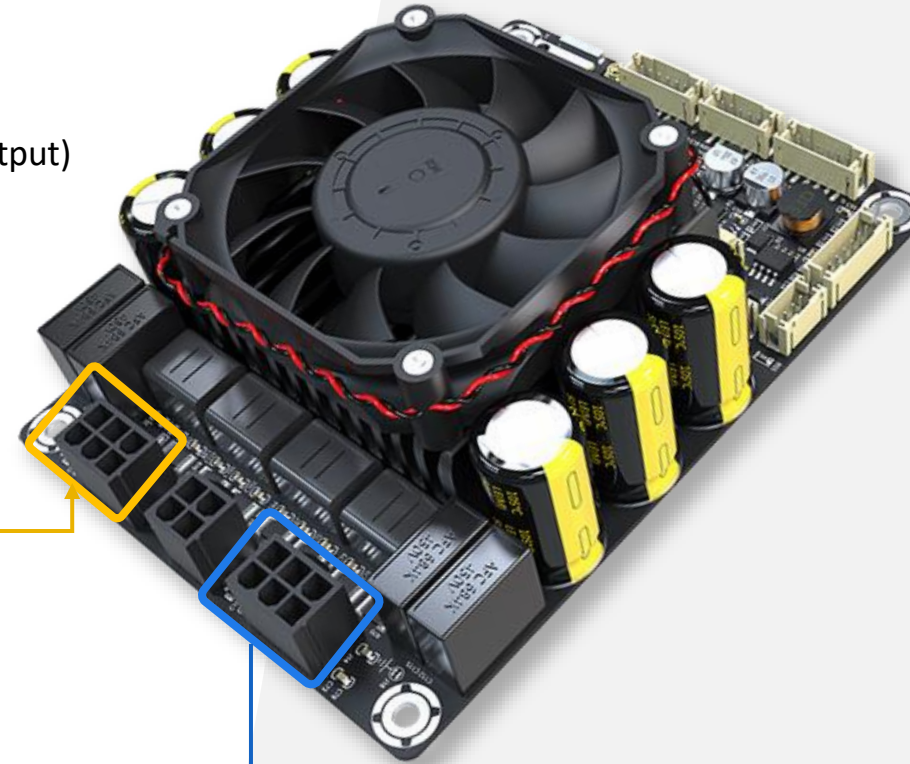

J14 - Speaker Output

GPIO_7 is used for detection of the state of J14.

J13 - Speaker Output

GPIO_0 is used for detection of the state of J13.



Audio Output – Speaker Output

Here is the block diagram of output for your reference.

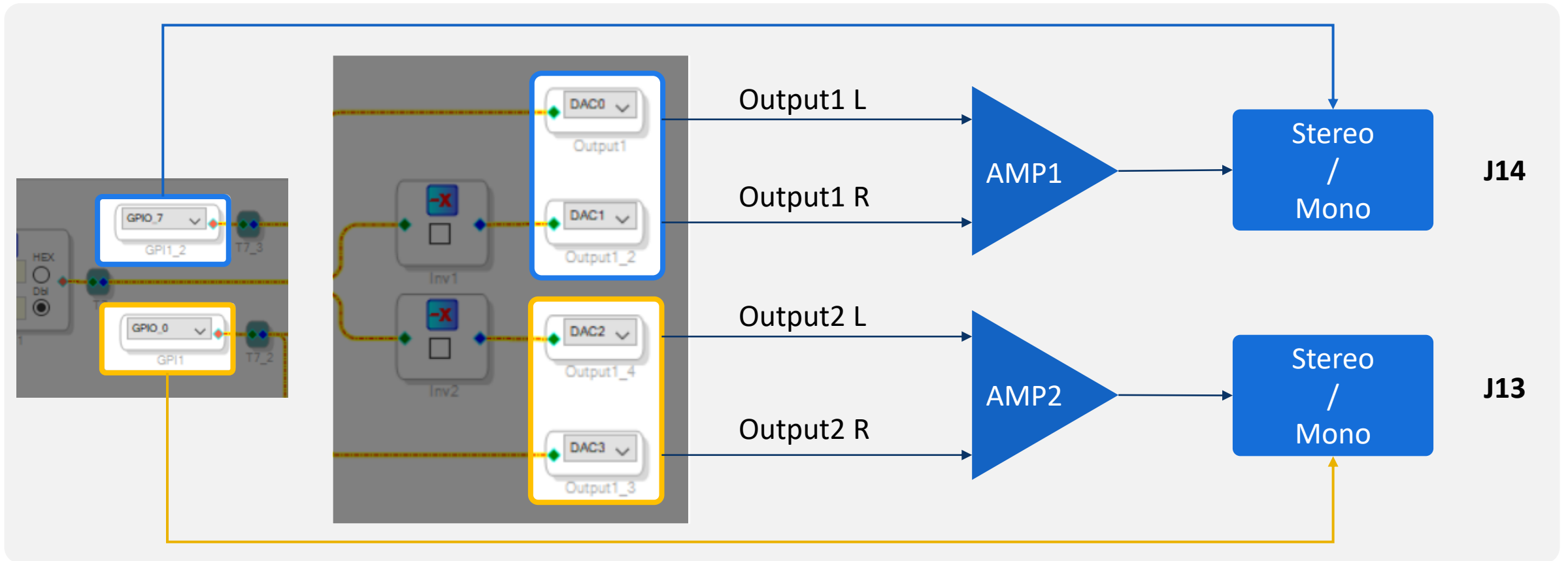

If the speaker output is set as mono, the R channel would be disabled.



Audio Output – I2S Output

In addition to speaker output, JAB5 provides a stereo I2S signal output for cascading with another JAB5 to build 8.0 or other systems. You can see it in the “Main” part in the demo program.

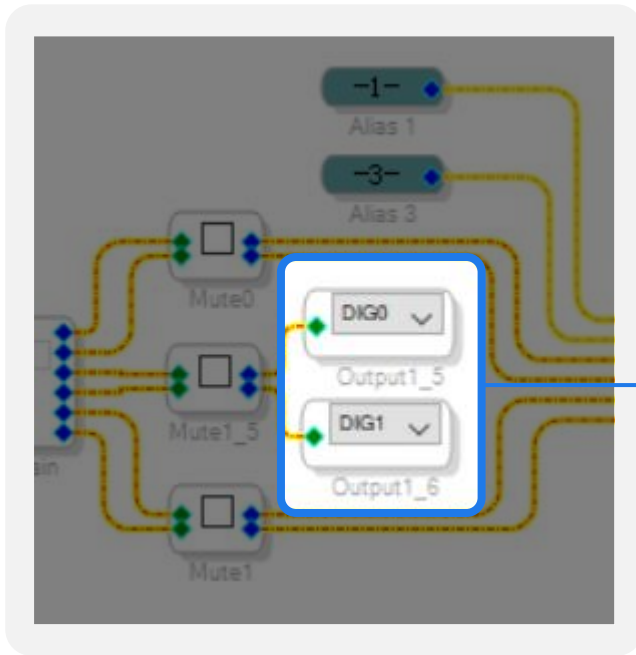

(Main)

J7 – I2S Output

I2S0 is corresponding with I2S signal output of JAB5.

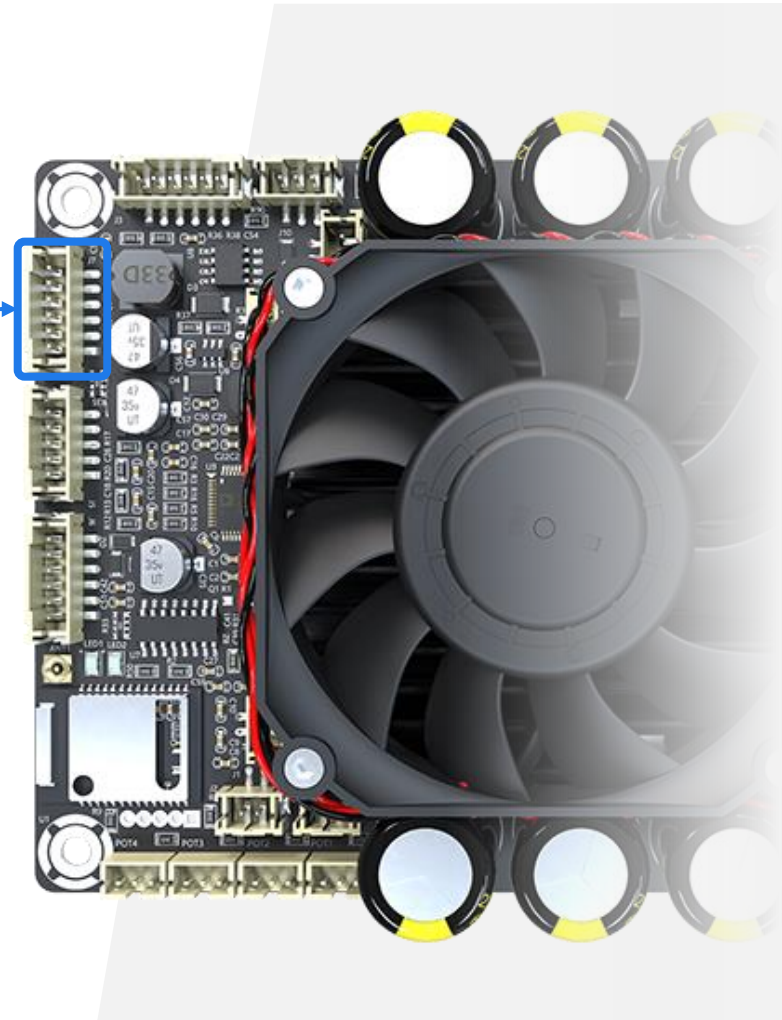



Potentiometers

Four ports for external potentiometers are provided on JAB5 for easy control of your audio system.

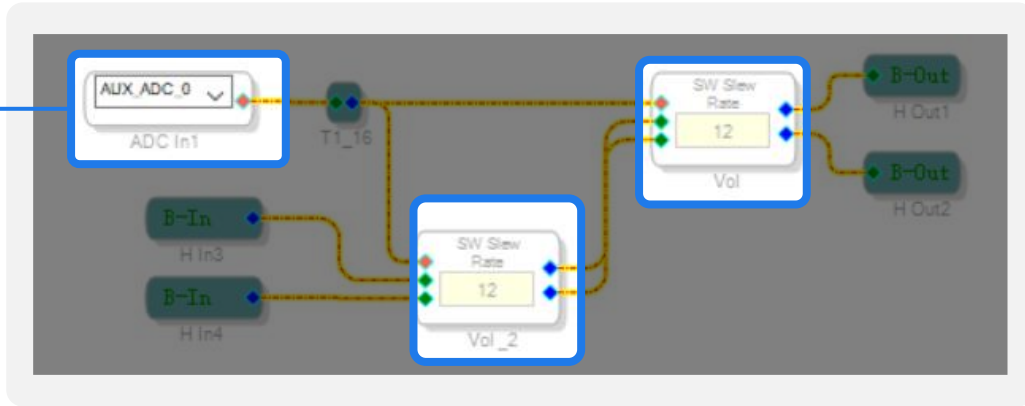

(Volume)

POT4
AUX_ADC_0 ---> POT4
Overall volume control

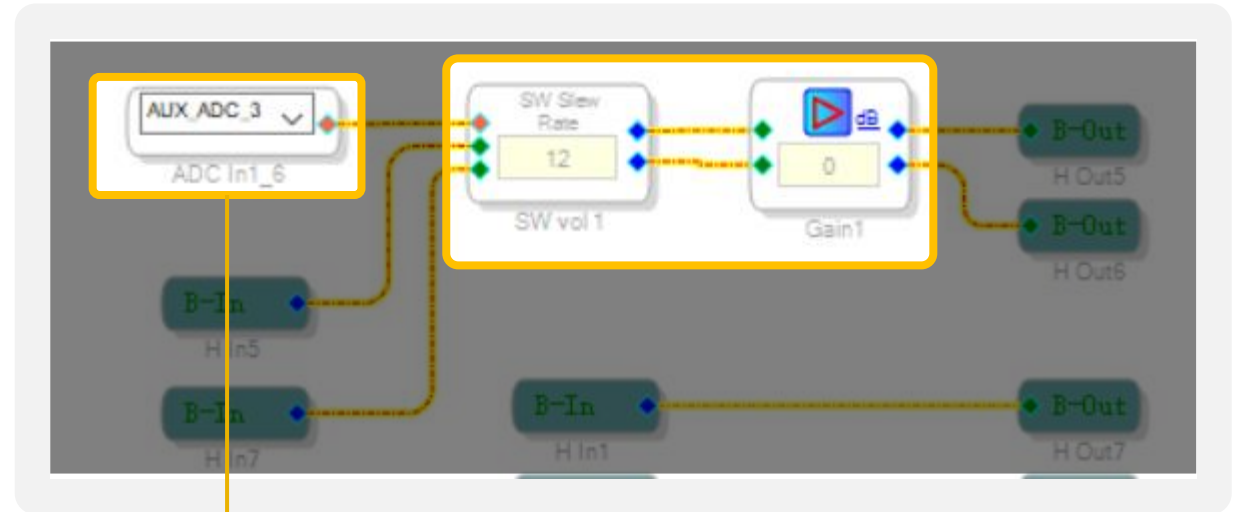

(Relative Gain)

POT1
AUX_ADC_3 ---> POT1
Relative gain of power amplifier 2



Signal Detection

Signal detection module is employed in the program. When the amplitude of the input signal exceeds -60dB, the signal would bypass JAB5 for 2s. This module is also responsible for noise suppression.

You can check it in the “Signal Detection” part.

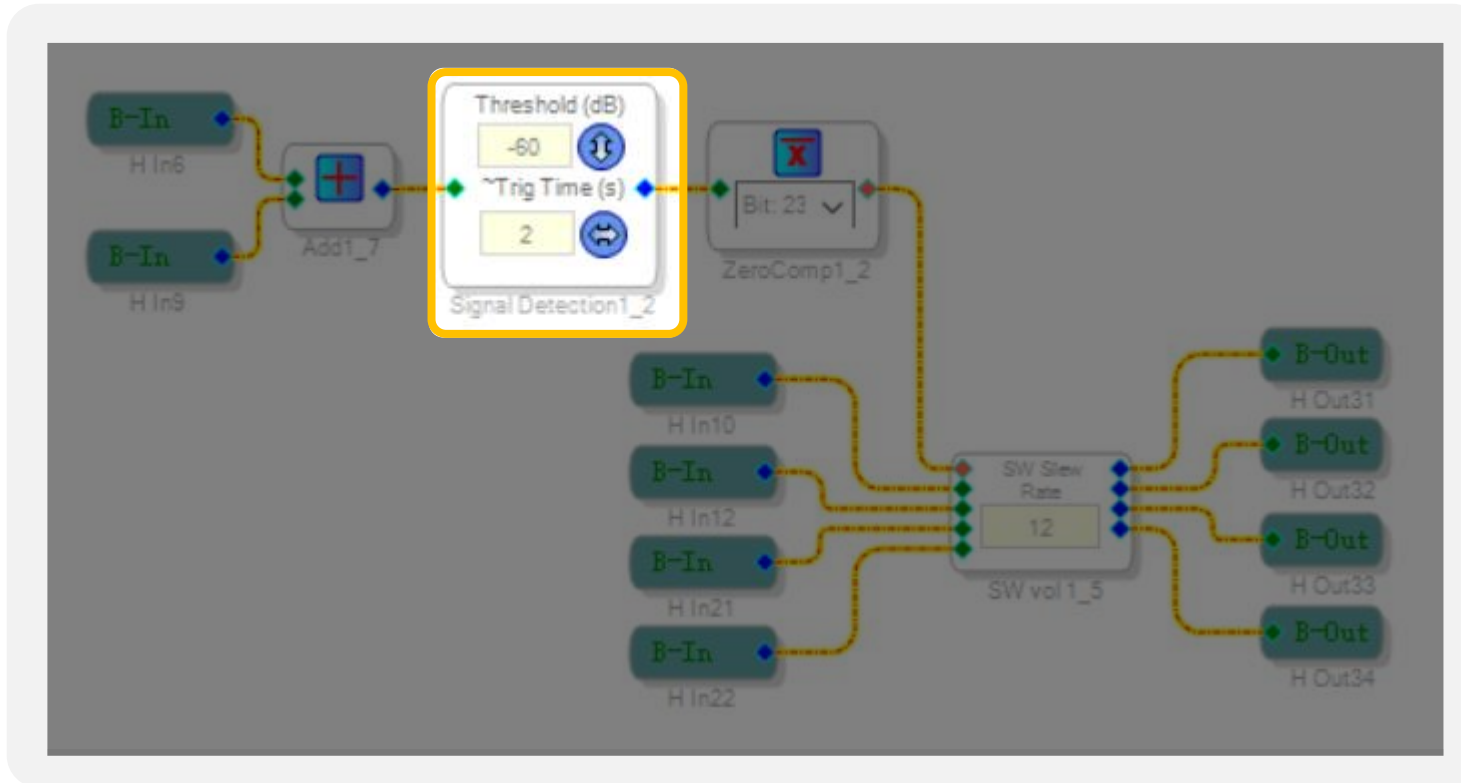

(Signal Detection)

Audio Setting When Programming

As we know, JAB5 is integrated with Bluetooth. Therefore, we need to set the audio configuration before programming. Otherwise, the Bluetooth would malfunction after programming.

As for the settings, you can find it in the “Hardware Configuration” – “IC 1 – 170x\140x Register Control” part in the demo program.

All the points in the yellow boxes are important. Please set them the same as what is shown.

The screenshot displays the 'Hardware Configuration' software interface. Key sections include:

- Serial Input (I2S):** Shows LRCLK polarity and BCLK data change waveforms. A yellow box highlights these waveform selection options.
- Serial Output 1 (channels 0-7):** Shows Master Mode, LRCLK polarity, BCLK polarity, Frame Sync Type (LRCLK), Frame Sync Freq. (internal clock/1), MSB Position (delay by 1), Word length (24 bits), and BCLK Frequency (internal clock/1). A yellow box highlights the waveform selection options.
- GPIO Configuration Table:** A table with columns for Pin, Value, Direction, and Inv. A yellow box highlights rows MP1 through MP6, and another yellow box highlights rows MP8 through MP11.
- Register Control:** A table listing registers for Core, GpioAll, SerialOut1, SerialInput, MpCfg0, MpCfg1, AnalogPower, and AnalogInterfa.

MP2, MP3, MP8 and MP9 are for potentiometers.

Program

Please do remember to set the input & Output module when programming.

Necessary Settings

You can refer to the demo program for the settings.

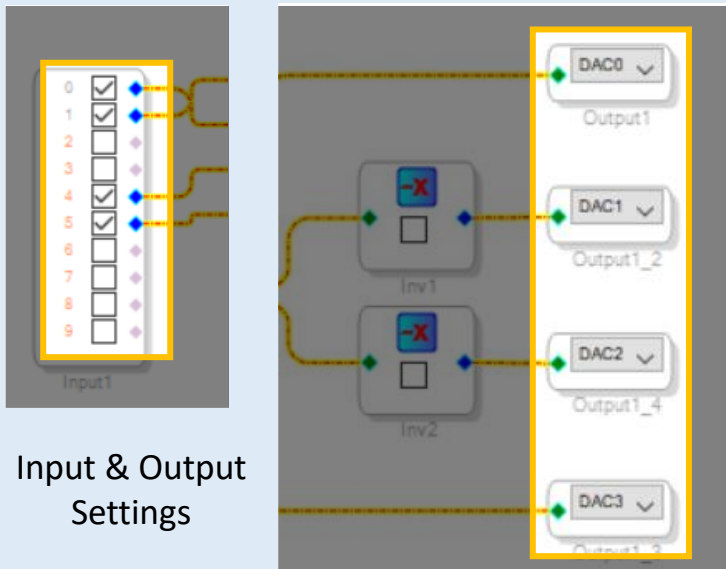

Optional Settings

You can add any function you want in the program, such as EQ, phase, frequency or volume. You can switch or change the functions of potentiometers in the program.

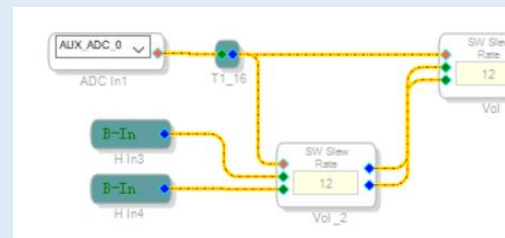

Recommended Functions

It is recommended to add a noise suppressor function in the program for a better sound quality.

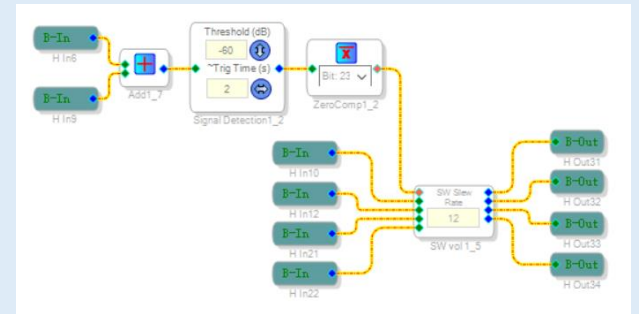

Summary

It is **HIGHLY** suggested that you directly make changes on the basis of our demo program.

